

S.NO	CATALOG NUMBER	L	A	B	C	CONDUCTOR SIZE	D-SIZE
1	WS-350I	2.63 [67]	1.19 [30]	1.13 [29]	1.38 [35]	350KCMIL-6	TAP 11/16-16
2	WS-250I	2.19 [56]	1.13 [29]	1.00 [25]	1.13 [29]	250KCMIL-6	TAP 5/8-18

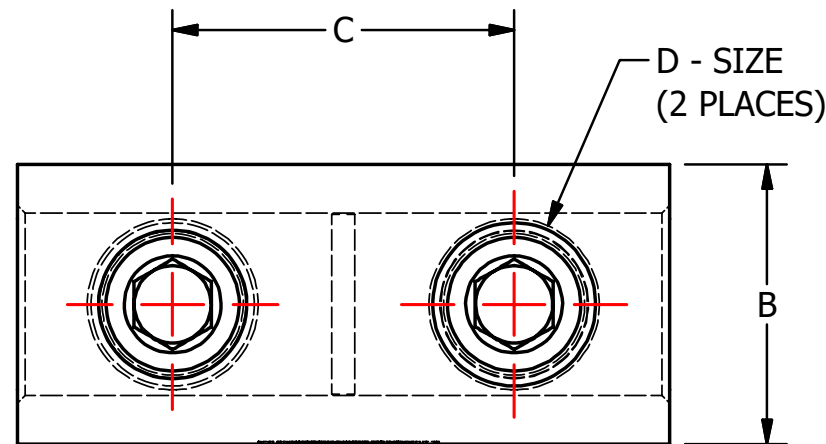

SCREWS ARE SUPPLIED WITH CONNECTOR AND COMES FULLY ASSEMBLED.

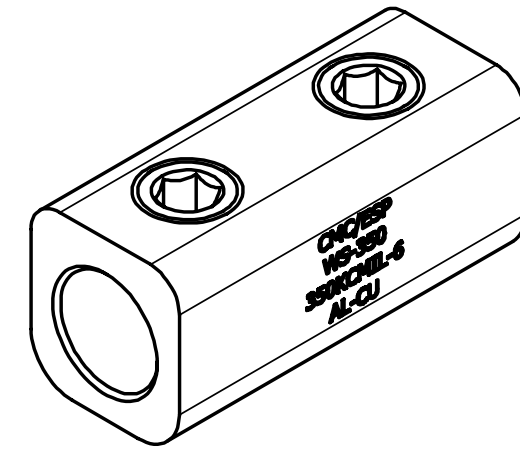
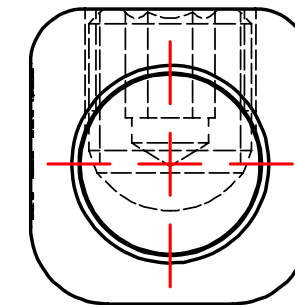
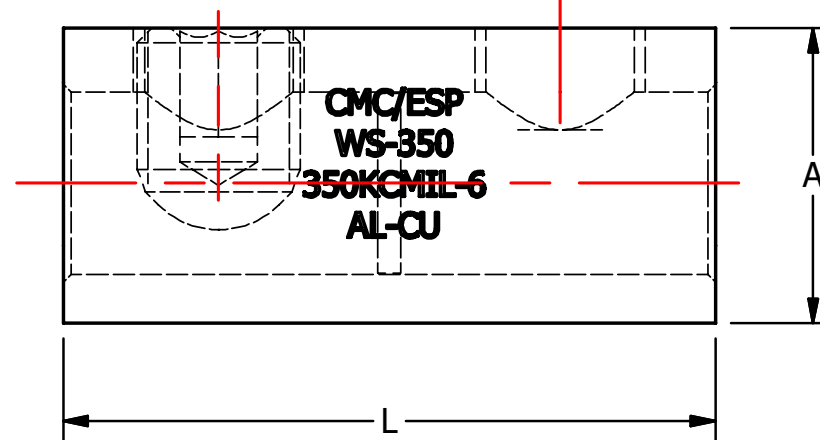
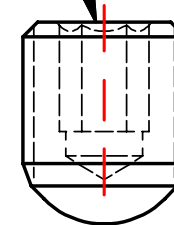
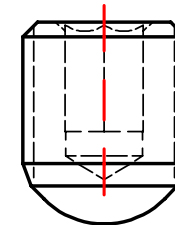

					TO ORDER CMC PRODUCTS CALL 1-513-860-4455	DRAWN BY: TS 02/20/19	NAME OF PART: LUG ASSEMBLY	CAT. NO.: SEE TABLE
					FOR PRODUCT INFO: http://www.cmclugs.com	CHECKED BY:	DWG NO: U08401640-S (CHARTED)	A
A	NEW DRAWING CREATED		02/12/19	TS		DRAWING NOT TO SCALE		SHEET NO: 1 OF 1
REV.	DESCRIPTION	ECN	DATE	INIT.				

